

Chloe

Fabric Collection by
Janet Broxon



FREE PATTERN
Ask for our fabrics
in your local
independent
quilt shop!

Size 15" x 12" x 6"
Bag designed by Heidi Pridemore



pbtex.com

Chloe's Backpack

Backpack by Heidi Pridemore using the *Chloe* fabric collection from P&B Textiles

Backpack Size: 15" x 12" x 6"

Materials

CHLO-493O - Orange Paisley Flowers: 1/2 yard

CHLO-494Y - Yellow Tonal Flowers: 1/2 yard

CHLO-491O - Orange Large Floral: 1/3 yard

CHLO-492Y - Yellow Chloe Stripe: 1/3 yard

CHLO-494YG - Green Tonal Flowers: 1 1/8 yards

You will also need:

Timtex: Two 3" x 4 1/2" pieces and two 3" x 9 1/2" pieces

1/8" thick Chipboard: One 6" x 12" piece

Fusible Web: 1 yard Cotton Batting

Cutting

Orange Paisley Flowers:

- Cut nine 1 1/2" x width of fabric (WOF) strips

Yellow Tonal Flowers:

- Cut nine 1 1/2" x WOF strips

Orange Large Floral:

- Cut one 9- 1/2" x WOF strip. Sub-cut the strip into two 9 1/2" x 12 1/2" pieces for the flap and one 6 1/2" x 12 1/2" piece for the bottom.

Yellow Chloe Stripe:

- Refer to the backpack photo for the section of stripe used for the top band. Fussy cut two 3" high x 9 1/2" wide strips for the front and back pieces and two 3" high x 4 1/2" wide strips for the side pieces

Green Tonal Flowers:

- Cut two 11 1/2" x 12 1/2" pieces for the front and back lining
- Cut one 6 1/2" x 12 1/2" piece for the bottomlining
- Cut two 6 1/2" x 11 1/2" piece for the side lining
- Cut two 3" x 9 1/2" pieces for the front and back top band lining
- Cut two 3" x 4 1/2" pieces for the side top band lining
- Cut two 4" x 26 1/2" pieces for the straps
- Cut one 12" x 24" piece to cover the cardboard insert.

Assembly Instructions

1. Starting with one 1 1/2" x WOF Orange Paisley Flower strip, sew together six Orange Paisley Flower Strips and six 1 1/2" x WOF Yellow Tonal Flowers strips, alternating them, to make one twelve strip set. Cut the sewn twelve strip set into two 11 1/2" high x 12 1/2" wide pieces for the front and back of the backpack.

2. Starting with one 1 1/2" x WOF Orange Paisley Flower strip, sew together three Orange Paisley Flower Strips and three 1 1/2" x WOF Yellow Tonal Flowers strips, alternating them, to make one six strip set.

3. Cut the sewn six strip set into two 11 1/2" high x 6 1/2" wide pieces for the sides of the backpack.

4. Layer each pieced section with a piece of cotton batting and quilt as desired. Layer the 6 1/2" x 12 1/2" Orange Large Floral strip with batting and quilt as desired.

5. Following the manufacturer's instructions, fuse each piece of the Chloe Stripe to the Timtex pieces to make the front, back and sides of the top band.

Chloe's Backpack

Continued

6. Take the quilted front panel from Step 5, use a gathering stitch and gather the 12 1/2" top edge of the panel to finish at 9 1/2" wide (Fig. 1). Sew the 3" x 9 1/2" front band from Step 6 to the gathered edge of the front panel (Fig. 2). Repeat to complete the back panel.

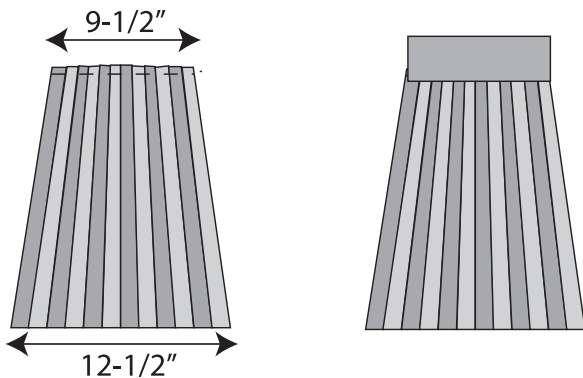

7. Take one quilted side panel from Step 5, use a gathering stitch and gather the 6 1/2" top edge of the panel to finish at 4 1/2" wide. Sew one 3" x 4 1/2" side band from Step 6 to the gathered edge of the side panel. Repeat to complete the other side panel.

8. To make the strap, center one piece batting 2" x 26 1/2" in the center of one 4" x 26 1/2" Green Tonal Flowers strip back sides together. Fold the 4" x 26 1/2" strip and batting in half lengthwise and press a center line. Open the folded strip and batting and fold the long edges in, aligning them with the center line and press. Fold the strip in half a second time and press to make one 1" x 26 1/2" strips with finished edges. Top stitch down each long side to make one strap. Repeat to make a second strap.

9. Position each strap on the quilted back piece, right sides together, at the bottom edge, positioning each strap about 1" in from the side edges. Let about 1" of the strap go past the bottom edge of the back panel, which will get caught in the seam when the bag is sewn together (Fig. 3).

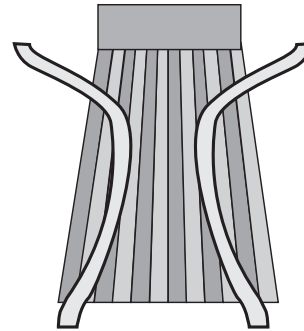

10. Align the bottom edge of the back panel with one 12 1/2" side of the quilted bottom panel, right sides together (Fig. 4). Starting and stopping a 1/4" from each edge sew the two pieces together. Repeat to add the front and two quilted side panels to quilted bottom piece.

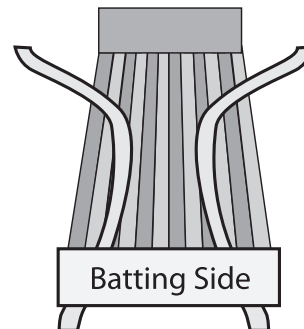

11. With right sides together, sew up each side seam on the backpack. Repeat Steps 7 -12 with the lining pieces to sew them together to create the lining. Leave a 4" opening in one of the side seams for turning the finished bag. Set the lining and bag aside.

12. To make the flap, place the two 9 1/2" x 12 1/2" Orange large Floral pieces right sides together. Place both pieces on top of a piece of batting. Trace the Flap Template onto the top piece of fabric and cut out through all three layers. Using a 1/4" seam allowance sew around the flap leaving the back straight edge of the flap open. Turn the flap right side out and quilt as desired.

Chloe's Backpack

Continued

13. Take the bag with straps and measure the straps on the user for desired length. Pin the top edge of the straps to the top edge of the Bag Band. Trim if needed leaving 1" extra on each strap.

14. Pin the flap to the back of the bag, right sides together, on top of the pinned straps and baste in place (Fig. 5).

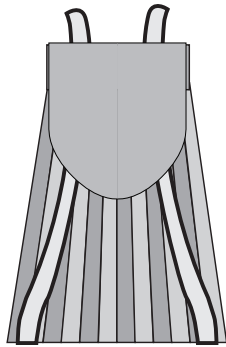

15. Slide the bag into the lining, right sides together. Sew around the top of both the bag and lining. Turn the bag right side out through the opening in the lining. Stitch the opening close.

16. Top stitch around the top of the Bag through the Timtex band.

17. Pinch each corner of the top band and sew down the band about $\frac{1}{8}$ " in from each corner seam, going through both adjacent sides to create a boxy look (Fig. 6).

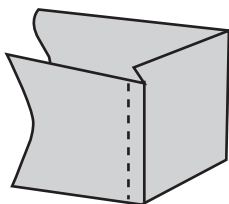

18. Fold in each 4" side panel of the top band 2" in from the corner to create a pleat. Sew down the folded top band about $\frac{1}{8}$ " from the fold (Fig. 7).

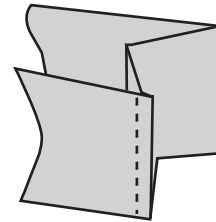

19. To make the cardboard bottom insert, following the manufacturer's instructions iron a piece of fusible web to the back side of the 12" x 24" Green Tonal Flower fabric.

20. Center the 6" x 12" piece of chipboard on the fabric. Following Figure 8, cut out the corners of the fabric.

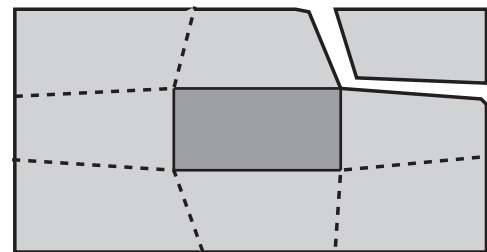

21. Wrap the fabric to the back of the cardboard and press in place. Insert the fabric covered cardboard into the backpack to give the bottom some shape.

Chloe's Backpack

Template

Trace template onto a folded piece of paper. Cut out through both layers and open for the template

Folded Edge

